

FACTORY ASSEMBLED MH CONNECTOR UNIT AS
MANUFACTURED AND DISTRIBUTED BY
CLARKS POTTERIES LTD.

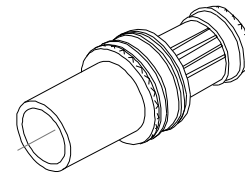
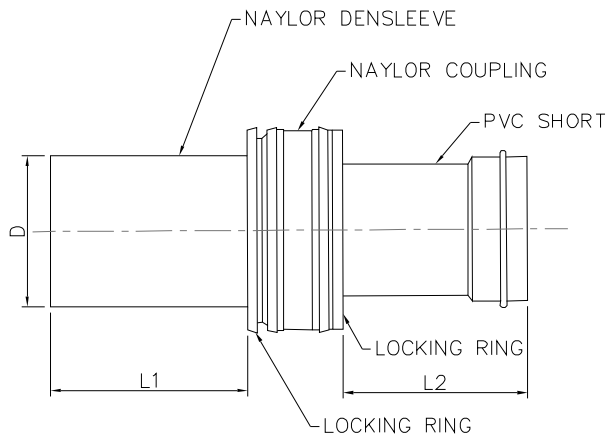

NOTES

1. ADAPTORS ARE TESTED TO AS/NZS 1260
2. NAYLOR DENSLEEVE PLAIN ENDED PIPE AND FITTINGS MANUFACTURED IN ACCORDANCE WITH REQUIREMENTS OF BS EN295-1
3. NAYLOR COUPLINGS MANUFACTURED IN HIGH IMPACT POLYPROPYLENE WITH ELASTOMERIC SEALS PROVIDING WATERTIGHT, FLEXIBLE MECHANICAL JOINT ASSEMBLY COMPLYING WITH BS EN 295-1:SYSTEM G
4. SEALS MANUFACTURED FROM ELASTOMERS CONFORMING TO PERFORMANCE REQUIREMENTS OF BS EN 681-1

DN(mm)	D(mm)	L1(mm)	L2(mm)
100	131	170	210
150	187	160	210

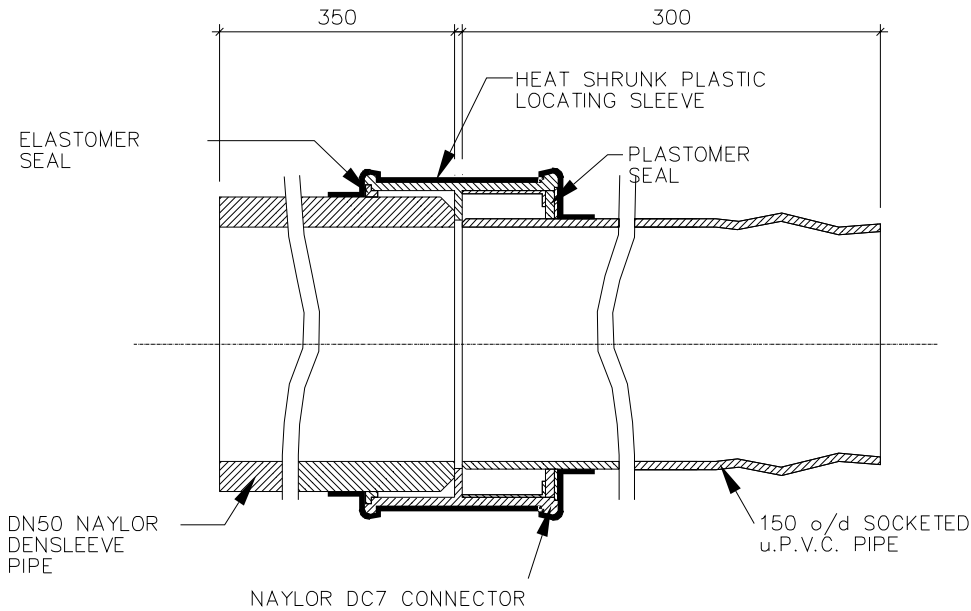

ASSUMED HUMES MANHOLE CONNECTOR



Head Office: 50 Centreway Road, Orewa
Private Bag 500, Orewa, 1461, New Zealand
Tel: 0800 4265169, Fax (09) 4267280
Email: info@rodney.govt.nz

26 February 2009

STANDARD DETAIL:
**MANHOLE INVERT
CONNECTORS**

Copyright on this Drawing is Reserved
DATE: DECEMBER 2008
NOT TO SCALE

RDC NO: SHEET NO: REV:

18000 5.1 1